

# Enpirion EV1340QI 5A DC/DC Converter with Integrated Inductor Evaluation Board

## Introduction

Thank you for choosing Altera Enpirion power products!

This user guide is applicable to evaluation boards with part number 05043 Rev A shown on the back side of the PCB. Along with this document you will also need the latest device datasheet.

- The EV1340QI features integrated inductor, power MOSFETS, Controller, bulk of the compensation Network, and protection circuitry against system faults. This level of integration delivers a substantial reduction in footprint and part count over competing solutions. The evaluation board is optimized for ease of use.
- The EV1340QI features a customer programmable output voltage by means of a resistor divider. This evaluation board, as shipped is populated with one option for  $V_{OUT}$ . It is programmed so that  $V_{OUT}$  will be half of  $V_{DDQ}$ .
- The EV1340QI includes the bulk of the compensation network internally. However, an external phase-lead (zero) capacitor and resistor is required in addition to two resistor dividers to set the output voltage. This network is shown in Figure -1. Appropriate component values allow for optimum compensation for a given  $V_{DDQ}$  voltage and choice of loop bandwidth. The values in Figure 1 are as populated on the eval board, and have been optimized for  $V_{DDQ} = 1.5V$ . The circuit in Figure 1 will be stable for lower values of  $V_{DDQ}$  as well. For  $V_{DDQ}$  higher than 1.5V, please see the datasheet to calculate the resistor divider and compensation values.
- Jumpers or test points are provided for ease of logical 1/0 programming of the following signals:
  - ENABLE (ENA)
  - EN\_PB inputENABLE may also be controlled using an external switching source by removing the jumper and applying the enable signal to the middle pin and ground.
- The board comes with input decoupling and reverse polarity protection to guard the device against common setup mishaps.

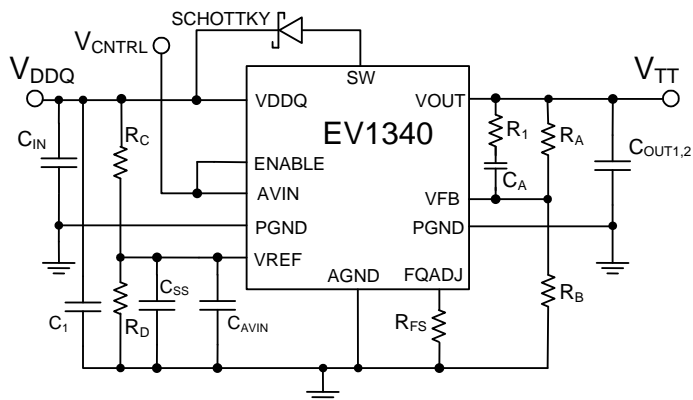

$$R_C = 15\text{ k}\Omega, R_D = 10\text{ k}\Omega$$

$$R_A = 150\text{ k}\Omega, R_B = 604\text{ k}\Omega$$

$$C_A = 33\text{ pF}, R_1 = 3.01\text{ k}\Omega$$

$$V_{\text{OUT}} = V_{\text{DDQ}} * \frac{R_D}{R_C + R_D} * \frac{R_A + R_B}{R_B}$$

With this circuit,  $V_{\text{OUT}}$  will be half of  $V_{\text{DDQ}}$ .

Figure 1: Output voltage programming and loop compensation

## Quick Start Guide

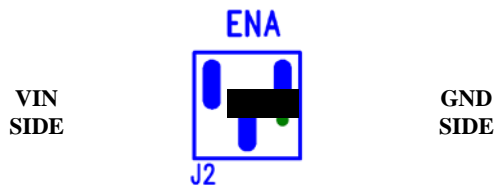

Figure 2: J2 allows control of the Enable pin.

The jumper on Enable pin as shown is in disable mode. When jumper is between the middle and right pins the signal pin is connected to ground or logic low. When the jumper is between the left and middle pins, the signal pin is connected to AVIN or logic High.

**WARNING:** complete steps 1 through 6 before applying power to the EV1340QI evaluation board.

**STEP 1:** Set the “ENA” jumper to the Disable Position. See Figure 2 above.

**STEP 2:** Set the EN\_PB jumper J1 to the desired position. See Figure 3. Pulling it low disables the pre-bias mode operation. Pulling this jumper high or letting it float will allow monotonic start-up with a pre-biased output. In pre-bias mode, VOUT will not discharge very quickly. Therefore, you may need to apply a small load (~10mA) at shut-down to ensure that the output voltage discharges. In Figure 3 the jumper is set low to disable pre-bias mode.

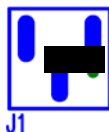

Figure 3: J1 controls EN\_PB input.

**CAUTION:** Except ENA, no other jumpers can be changed while the EV1340QI is powered on. Doing so could result in damage to the part.

**STEP 4:** Connect the VDDQ Power Supply to the input power connectors, VDDQ (J13) and GND (J7) as indicated in Figure 4 and set the power supply to the desired voltage ( $\leq 1.8V$ ). For VDDQ more than 1.5V, the loop compensation values will have to be adjusted according to the datasheet.

**CAUTION:** Be mindful of the polarity and magnitude. Even though the evaluation board comes with reverse polarity protection diodes, it may not protect the device for all conditions.

**STEP 5:** Connect AVIN power supply to the input connectors AVIN (J15) and GND (J7) as indicated in Figure 4 and set the power supply to the desired voltage (3.3V nominal).

**CAUTION:** The AVIN power connection on this board has no reverse polarity or voltage clamping protection on it.

**STEP 6:** Connect the load to the output connectors VOUT (J4) and GND (J6), as indicated in Figure 4.

**STEP 7:** Power up the board by turning on the AVIN power supply first and then the VDDQ supply. Next, move the ENA jumper to the enabled position. The EV1340QI is now powered up and VOUT should be half of VDDQ. You are free to make Efficiency, Ripple, Line/Load Regulation, Load transient, Power OK, and temperature related measurements.

**STEP 7A: Power Up/Down Behavior** – Remove ENA jumper and connect a pulse generator (output disabled) signal to the middle pin of ENA and Ground. Set the pulse amplitude to swing from 0 to 2.5 volts. Set the pulse period to 10msec, duty cycle to 50% and fast transition ( $< 1\mu\text{sec}$ .) Hook up oscilloscope probes to ENA, POK and  $V_{\text{OUT}}$  with clean ground returns. Enable pulse generator output. Observe the  $V_{\text{OUT}}$  voltage ramps as ENA goes high and again as ENA goes low.

**STEP 8:** You can also operate the board by leaving the ENA jumper in the high position. Then apply AVIN to the board. Next, turn on the VDDQ supply. The output will ramp up and down as half of VDDQ all the time.

**CAUTION:** If the device is powered up into a short-circuit condition, it is susceptible to damage. Customers are advised to limit the VDDQ power supply compliance to an acceptable level to mitigate this issue.

**ALWAYS power down device before changing any board level components!**

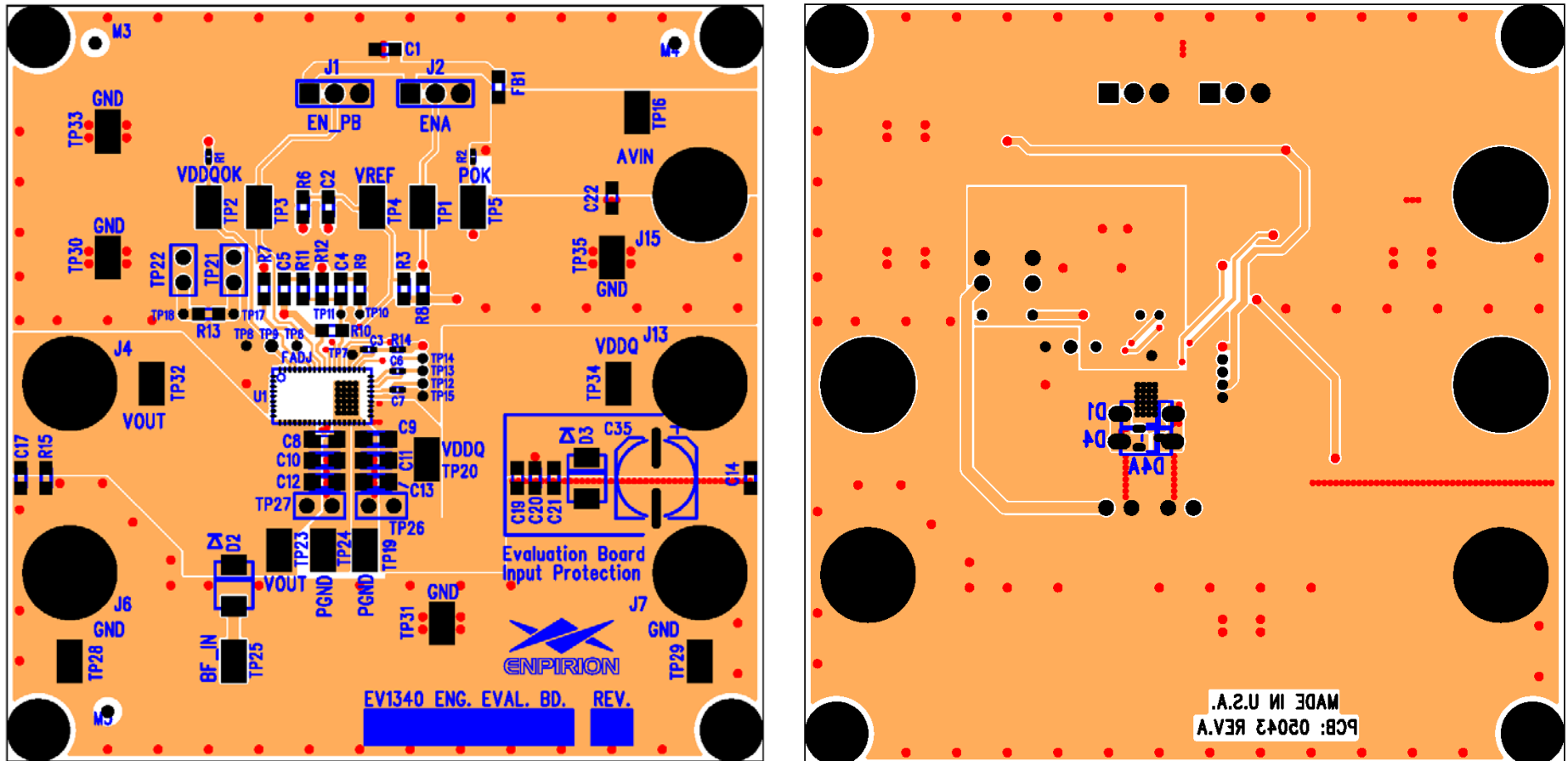

Figure 4: Evaluation Board Top Side and Bottom Side (viewed from the top) Assembly Layers.

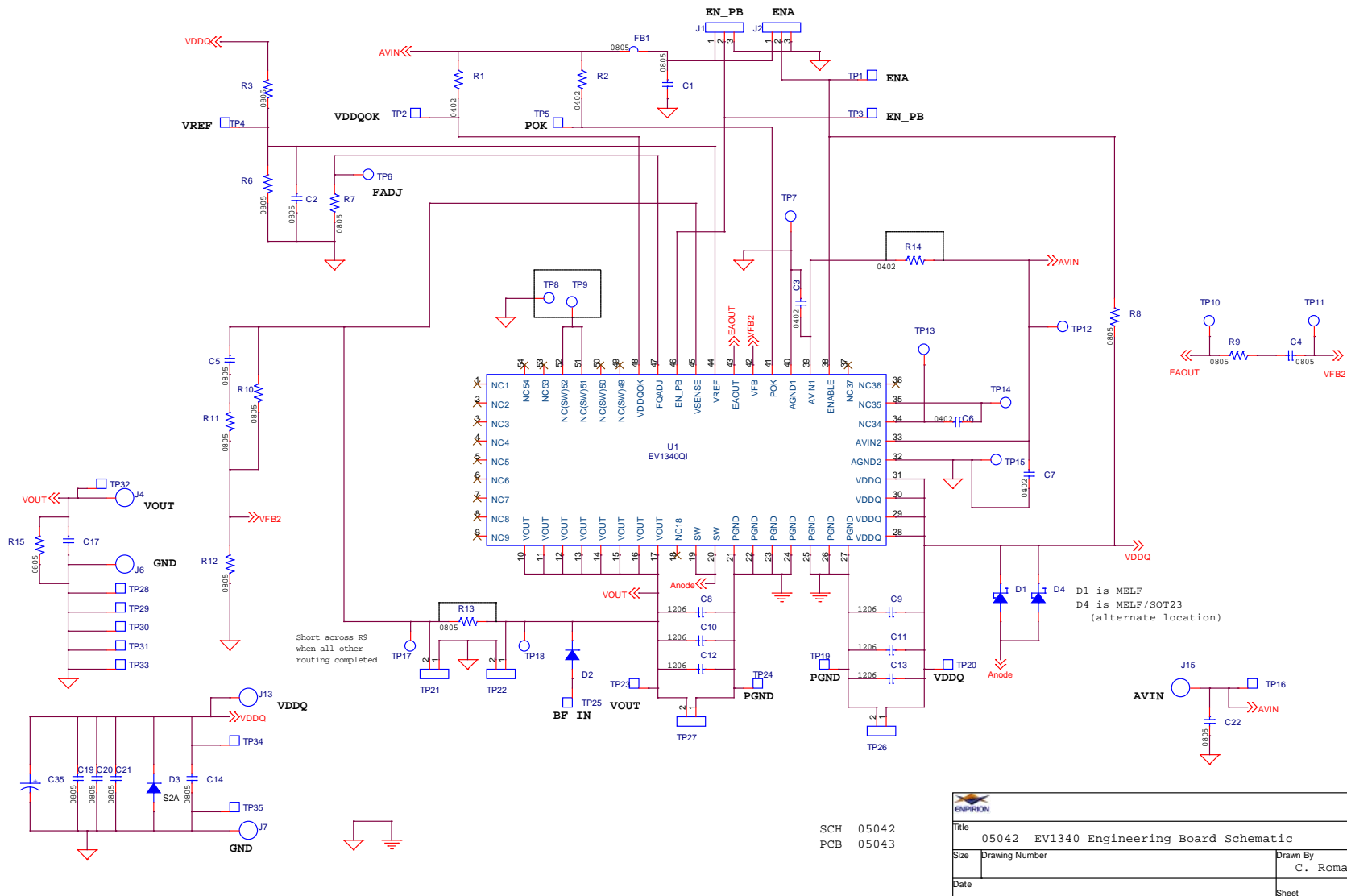
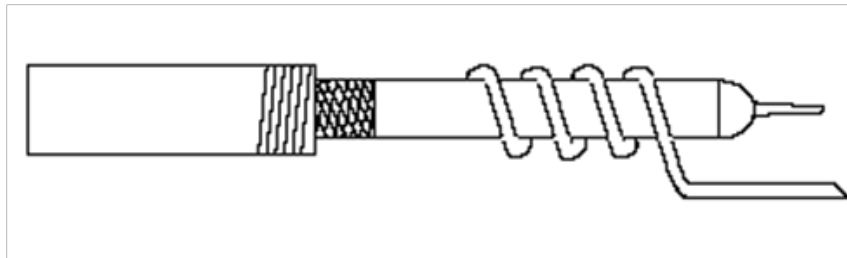

Figure 5: Evaluation Board Schematic

## Test Recommendations

To guarantee measurement accuracy, the following precautions should be observed:

1. Make all input and output voltage measurements at the board using the surface mount test points TP19, TP20, TP23, and TP24 provided. This will eliminate voltage drop across the line and load cables that can produce false readings.
2. Measure input and output current with calibrated series ammeters or accurate shunt resistors. This is especially important for measuring efficiency.
3. Use a low-loop-inductance probe tip similar to one shown below to measure  $V_{OUT}$  and switching signals to avoid noise coupling into the probe ground lead. Output ripple and load transient deviations are conveniently measured at TP27. For more accurate ripple measurement, please refer to Enpirion App Note regarding this subject ([www.altera.com/enpirion](http://www.altera.com/enpirion)).



4. The board includes a pull-up for the POK signal and ready to monitor the power OK status.
5. A soft-start capacitor is populated on the board to provide a reasonable soft-start time. It can be changed as needed.

## Input and Output Capacitors

Please refer to the BOM section for the value of input caps and output caps used on this evaluation board. Capacitors must be X5R or X7R dielectric formulations to ensure adequate capacitance over operating voltage and temperature ranges.

## Bill of Materials

Designator	Qty	Description
C1, C19–C22	5	CAP, 10uF 0805 X7R 10% 10V CERAMIC
C2	1	CAP, 3300pF 5% 50V 0805 COG
C5	1	CAP CERAMIC 33PF 50V NP0 0805
C8, C10	2	CAP, CER 100UF 6.3V X5R 1206
C9	1	CAP, CER 47UF 6.3V X5R 0805
C35	1	CAP, SMT ELECTROLYTIC, 150UF, 20%, 10V
C3, C4, C6, C7, C11–C14, C17, D4, R8, R9, R13–R15	15	NOT USED
D1	1	DIODE SCHOTTKY 1A 40V MELF, TMBYV10-40FILM
D2, D3	2	S2A DIODE
FB1	1	SMT FERRITE BEAD 4A 0805, WURTH ELECTRONIK 742792012
J1, J2	3	CONN HEADER, VERTICAL, 3 POSITION, 0.100", TIN
J4, J6, J7, J13, J15	5	BANANA JACK, KEYSTONE 575-4
R1, R2	2	RES 100K OHM 1/16W 1% 0402 SMD
R3	1	RES 1/10W 15K OHM 0.1% 0805
R6	1	RES 10 K OHM 1/8W 0.1% 0805 SMD
R7	1	RES 3.57K OHM 1/8W 1% 0805 SMD
R10	1	RES 150K OHM 1/8W 0.1% 0805 SMD
R11	1	RES 3.01K OHM 1/8W 1% 0805 SMD
R12	1	RES 604K OHM 1/8W 0.1% 0805 SMD
TP1-TP5, TP16, TP19, TP20, TP23-TP25, TP28-TP35	19	TEST POINT SURFACE MOUNT, KEYSTONE 5016
U1	1	EV1340QI QFN 5A

## Contact Information

Altera Corporation  
101 Innovation Drive  
San Jose, CA 95134  
Phone: 408-544-7000  
[www.altera.com/](http://www.altera.com/)

© 2013 Altera Corporation—Confidential. All rights reserved. ALTERA, ARRIA, CYCLONE, ENPIRION, HARDCOPY, MAX, MEGACORE, NIOS, QUARTUS and STRATIX words and logos are trademarks of Altera Corporation and registered in the U.S. Patent and Trademark Office and in other countries. All other words and logos identified as trademarks or service marks are the property of their respective holders as described at [www.altera.com/common/legal.html](http://www.altera.com/common/legal.html). Altera warrants performance of its semiconductor products to current specifications in accordance with Altera's standard warranty, but reserves the right to make changes to any products and services at any time without notice. Altera assumes no responsibility or liability arising out of the application or use of any information, product, or service described herein except as expressly agreed to in writing by Altera. Altera customers are advised to obtain the latest version of device specifications before relying on any published information and before placing orders for products or services.